

User's Manual

VA720 Series

Fiber Optic Video /Audio Bi-Directional

Installation and User Guide

Revision 2.0 FEB 2006

VAB720 Series Users and Installation Manual

Radiant Communications makes every effort to ensure that this document is accurate. However, because we are always improving our products, we are unable to guarantee the accuracy of the contents of this document after the date of publication and we disclaim liability for any changes, error or omissions.

Copyright

Copyright © 1999 by Radiant Communications. Printed in the United States of America. No part of this publication may be reproduced, stored in a retrieval system, or transmitted, in any form or by any means, electronic, mechanical, photocopying, recording, or otherwise, without written permission of the publisher.

All rights reserved, VAB720 Series User's Manual

Limitation of Liability

In no event shall Radiant Communications be liable for any defect in hardware or software or loss or inadequacy of data of any kind, or for any direct, indirect, incidental, or consequential damages in connection with or arising out of the performance or use of any product furnished hereunder. Radiant Communication's responsibility shall in no event exceed the purchase price of the product purchase hereunder. The foregoing limitation of liability shall be equally applicable to any service provide by Radiant Communications or its authorized agent.

TABLE OF CONTENTS

1 SAFETY INSTRUCTIONS

2 INTRODUCTION

- 2.1 System Configuration
 - 2.1.1 Video/Audio Transmitter
 - 2.1.2 Video/Audio Receiver Front View
 - 2.1.3 Video/Audio Receiver Rear View
- 2.2 Equipment Description
 - 2.2.1 Base Model Descriptions
- 2.3 Example Applications

3 INSTALLATION

- 3.1 Unpacking The Unit
- 3.2 General Installation
- 3.3 Power Connection
 - 3.3.1 Receiver
 - 3.3.2 Transmitter
- 3.4 Fiber Optic Cables Connection
- 3.5 Fiber Optic Ports
- 3.6 Video Cables
- 3.7 Audio Connections
 - 3.7.1 Differential (Balanced)
 - 3.7.2 Singled Ended (Unbalanced)

4 OPERATION

- 4.1 Turn On Procedure

TABLE OF CONTENTS

5 MAINTENANCE and TROUBLESHOOTING

- 5.1 Maintenance
- 5.2 Troubleshooting

6 SPECIFICATIONS

- 6.1 Technical specifications

7 CUSTOMER SUPPORT

- 7.1 Return Policy
- 7.2 Advance Replacement Policy
- 7.3 Warranty Policy

1 SAFETY INSTRUCTIONS

THE VAB720 SYSTEM MAY CONTAIN A CLASS IIIb LASER. PLEASE OBSERVE THE FOLLOWING SAFETY PRECAUTIONS THAT APPLY TO LASER EQUIPED UNITS.

WARNING: Do not disconnect the fiber optic external connector with the power turned on. Exposure to Class IIIb Laser radiation is possible when the external fiber connector is disconnected while the unit is still powered up. Ensure the rubber boot is in place whenever the fiber optic cable is disconnected.

CAUTION: Attempting to make adjustments or performing operations other than those specified may result in hazardous radiation exposure. Exposure for only seconds can cause permanent eye damage as well as other injuries.

2 INTRODUCTION

This manual is a guide to the installation, operation, applications and maintenance of the VAB720 series fiber optic video optic transmission system.

2.1 System Configuration Overview

2.1.1 Video / Audio Transmitter Front

The VAB720T and the VAB720R share the same indicator panel. The indicators provide information regarding the local optical link, the optical link at the remote end (relative to observer) and presence of video and data activity. The front and rear panels are shown below:

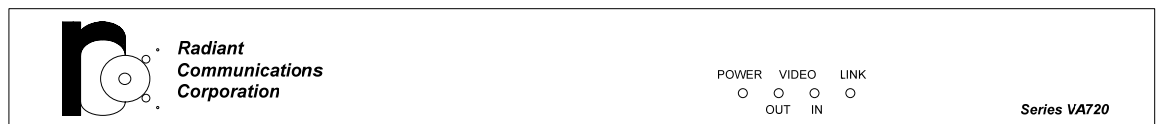

VAB720 FRONT VIEW

Optical Transmission Link Indicators:

The presence of Local Link (LLINK) on the front panel indicates that the INCOMING optical digital signal is synchronized and being received without errors. In order for ANY OTHER INDICATORS to be valid, the LLINK LED must be illuminated GREEN.

The Remote Link Indicator (RLINK) indicates that the remote end's (relative to observer) optical digital signal is synchronized at the remote end and is being received without errors. This indicator allows the user to check the optical transmission status in both directions from one end of the system.

2.1.2 Video / Audio Rear View

The VAB720T and the VAB720R also have the same rear panel, with the exception of the VAB720T provides a Video Input BNC and the VAB720R provides a Video Output BNC. The rear panel is depicted below:

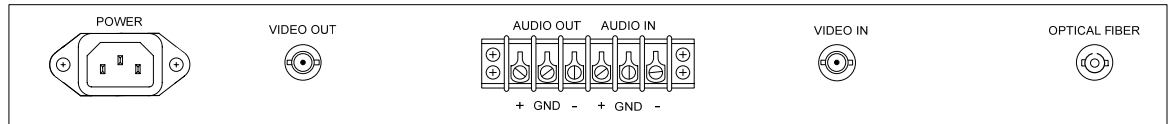

VAB720 REAR VIEW

2.2 Equipment Description

The system is capable of transmitting and receiving 1 simplex video signal and 2 duplex audio channels over 1 or 2 optical fibers.

Depending on the distance requirements between sites, the VAB720 Series may be equipped to operate over multi-mode fiber or equipped to operate over single mode fiber. Distances between the transmitter and receiver can be up to 10 Km for multi-mode operation and up to 80 Km for singlemode operation.

The VAB720 system employs uncompressed analog to digital modulation techniques, which provides for superior receiver output stability and is unaffected by changes in the fiber path attenuation caused by environmental factors, splicing or aging.

The VAB720T accepts the baseband video signal for transmission via an optical digital carrier over a single optical fiber. At the distant end, the VAB720R receiver accepts the optical carrier and converts it to the output video channels.

2.2.1 VAB720 SERIES BASE MODELS

The VAB720 Series always includes simplex video. The following table describes the base model Options:

<u>Tx Model</u>	<u>Rx Model</u>	<u>Description</u>
CCTV Versions:		
VA720M2-T-XYZ	VA720M2-R-XYZ	DUEL FIBER MM
VA720M1-T-XYZ	VA720M1-R-XYZ	SINGLE FIBER MM
VA720S2-T-XYZ	VA720S2-R-XYZ	DUEL FIBER SM
VA720S1-T-XYZ	VA720S1-R-XYZ	SINGLE FIBER SM

Broadcast Versions:		
VAB720M2-T-XYZ	VAB720M2-R-XYZ	DUEL FIBER MM
VAB720M1-T-XYZ	VAB720M1-R-XYZ	SINGLE FIBER MM
VAB720S2-T-XYZ	VAB720S2-R-XYZ	DUEL FIBER SM
VAB720S1-T-XYZ	VAB720S1-R-XYZ	SINGLE FIBER SM

Model Notes:	
VA720	Video uses 8 Bit CODEC
VAB720	Video uses 10 Bit CODEC (Broadcast Quality)
X	M -MODULAR R -RACK MOUNT U -1U CHASSIS
Y	D - ST, B -FC, E -SC/UPC A -SC/APC S -FCNAPC
Z	Wavelength (Varies by Model) 1 -850 2 -1300 3 -1310 5 -1550

2.3 Example Applications

Example Application 1: Simplex Video with Duplex Audio

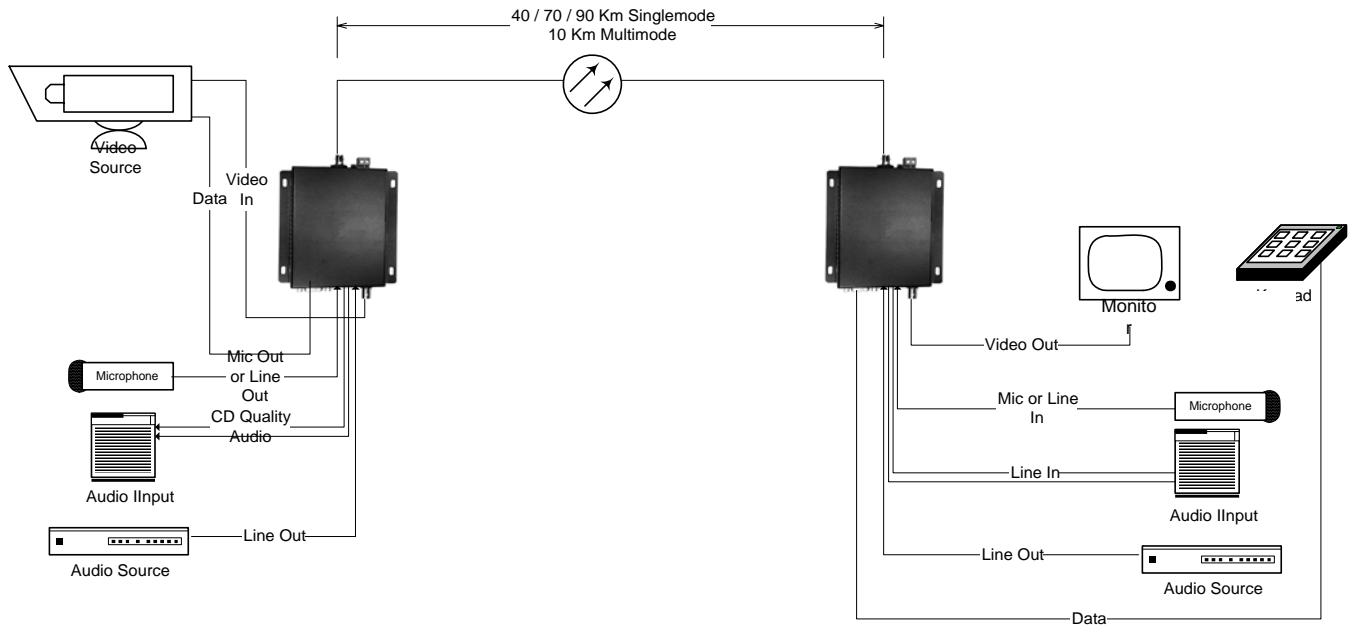

3 INSTALLATION

3.1 Unpacking The Unit

Remove all materials from the packing box and confirm receipt of the following:

- VAB720-T transmitter (Standalone, Rack mount, 1U)
- VAB720-R Optical Receiver (Standalone, Rack mount, 1U)
- A/C power cord/Power Cube.
- User's manual.

In the unlikely event that anything is missing, contact your authorized ACL dealer or representative. If it becomes necessary to return the unit(s), repackage the unit in its original box.

3.2 General Installation

Make sure that there is enough space to pull and connect the BNC video source, BNC output cables and optical cables without stressing them beyond the manufacturer's limitation (minimums bend radius).

Install the VAB720 stand alone units such that the environmental specifications are not exceeded.

NOTE: Install the VAB720 such that ventilation is present as this will minimize the possibility of component failures and increase system reliability.

3.3 Power Connection

3.3.1 Stand Alone

DC Power connections are made by connecting the 12-16 volts DC @ 1A to the corresponding terminal block connections on the rear of the VAB720 as shown below:

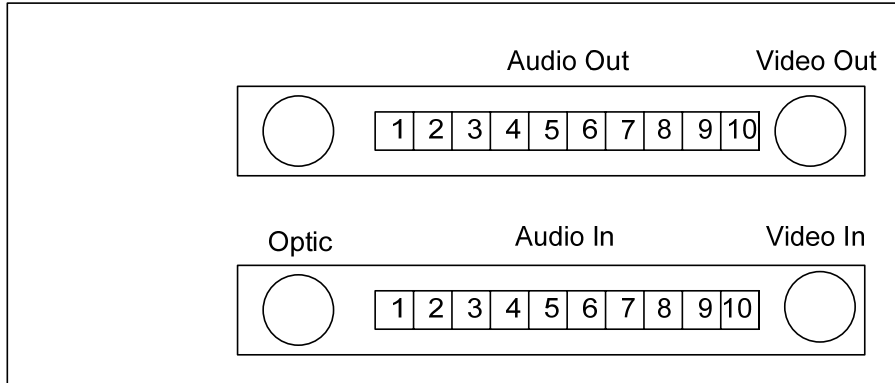

Pin No.	Description
1	Audio 1 +
2	Audio 1 -
3	GND
4	N/C
5	N/C
6	N/C
7	N/C
8	N/C
9	N/C
10	GND

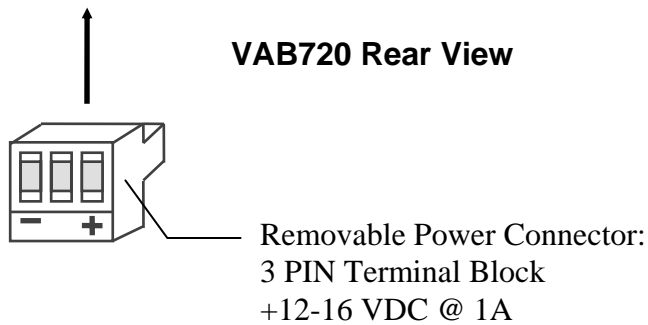

The Green LED indicator labeled "PWR" should now be on.

3.3.2 Rackmount Chassis

Slide the VAB720 Rack mount Card into an empty slot. Push firmly to ensure that the card is properly seated into the card slot.

The VAB720 Rack mount Card is hot swappable and may be inserted or removed when power is applied to the chassis.

When power is applied to the chassis, the PWR LED indicator on the VAB720 Rack mount Card will illuminate indicating that the card is powered on.

The chassis power supply is designed for operation over an AC input range of 90 VAC to 240 VAC and input frequency from 47 Hz to 63 Hz and is equipped with a standard IEC three prong power plug which will only fit a grounding type AC outlet.

Note: Do not defeat the purpose of the AC chassis grounding plug or equipment damage may occur

VAB720 Series Installed in 19" EIA Chassis

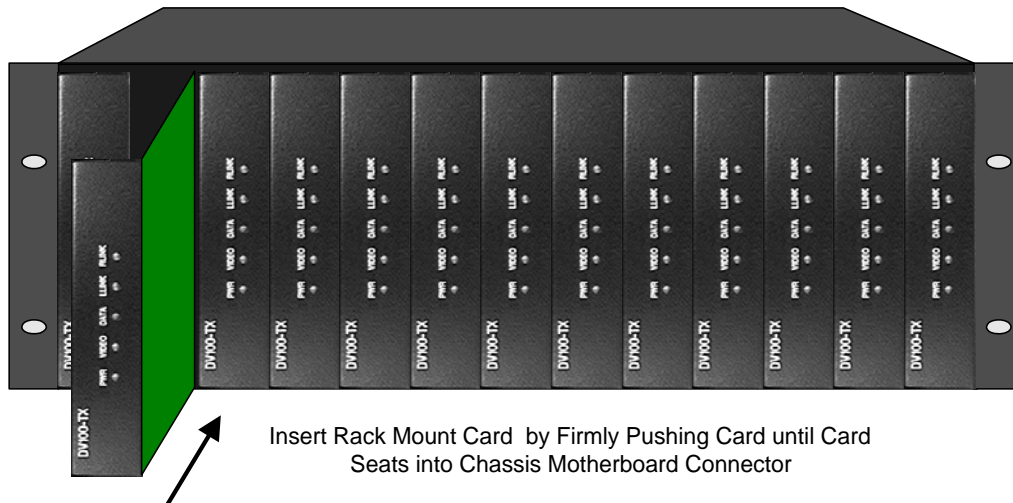

3.4 Fiber optic cable connection

The VAB720 Series has the following optical connection options:

- a. ST
- b. FC
- c. SC
- d. SCAPC
- e. FCNAPC

In order to connect the VAB720 Series to the fiber optic cable plant, a compatible fiber optic jumper must be used.

Note: Clean fiber optic jumpers increase transmission distance and reduce reflections.

3.5 Fiber Optic Ports

The following describes the steps required to connect the VAB720 Series Transmitter and Receiver to the fiber optic cable plant.

- a. Proper optical fiber connection between the transmitter and the receiver is to label each individual cable for each channel.
- b. To make connections:
 - . Clean the port: First remove and save the dust caps from the optical port of both the converter and the user device. Wipe the inside of the sleeve with a lint-free pipe cleaner moistened with reagent-grade isopropyl alcohol. Blow dry with dry air.
 - . Clean the connector: Use lint-free cloth dampened with alcohol to thoroughly wipe the side and end of the ferrule. Blow the ferrule dry with dry air. Visually inspect the ferrule for lint.
 - . To insert connector:

ST-type: Hold the connector by the strain-relief boot and insert the connector ferrule into the port. Rotate the boot until the “key” engages in the slot of the coupling. Push the connector housing forward until it can be turned clockwise to latch to the port.

FC-type: Holding the connector by the strain-relief boot and insert the connector ferrule into the port. Rotate the boot until the “key” engages in the slot of the coupling. Push the connector housing forward and screw turned clockwise until it is tied.

SC Type: Align the SC fiber optic jumper's SC connector such that the SC Key is on top. Align the jumper's ferrule with the VAB720 Fiber Optic port and insert the ferrule. Firmly push the SC jumper's connector all the way into the VAB720 optical SC mating port until the connection clicks into place. Measure the optical output power with an optical power meter to ensure that a low loss connection has been made.

SCAPC Type: See Align the SCAPC fiber optic jumper's SCAPC connector such that the SC Key is on top. Align the jumper's ferrule with the VAB720 Fiber Optic port and insert the ferrule. Firmly push the SCAPC jumper's connector all the way into the VAB720 optical SCAPC (GREEN) mating port until the connection clicks into place. Measure the optical output power with an optical power meter to ensure that a low loss connection has been made. Note: Never mate angle jumpers(Green Boot) with unangled/Flat UPC jumpers(Blue Boot).

FCNAPC Type: Holding the connector by the strain-relief boot and insert the connector ferrule into the port. Rotate the boot until the “key” engages in the slot of the coupling. Push the connector housing forward and screw turned clockwise until it is tied. Note: Never mate angle jumpers(Green Boot) with untangled/Flat UPC jumpers(Blue Boot).

3.6 Video Connections

Video signals are sent over a **75 ohm coax cable terminated in a BNC connector** (e.g. RG 59U with a BNC connector), as follows:

- a. For the VAB720T, connect the video source to the VIDEO IN BNC connector.
- b For the VAB720R, connect from the VIDEO OUT BNC to the Video Input Equipment

3.7 Audio Connection

The VAB720 Models have a single channel of audio for both transmit and receive. The VAB720 supports both balanced audio and unbalanced audio. Accessing the audio I/O requires connecting balanced or unbalanced audio. The audio input and output impedance is 600ohms (10k Ohm upon request -Factory Configured). For unbalanced audio(2 wire), jumper pin2 to pin 3 (negative audio to Ground) on both Transmit and Receive audio channels.

<u>Pin No.</u>	<u>Description</u>
1	Audio 1 +
2	Audio 1 -
3	GND
4	N/C
5	N/C
6	N/C
7	N/C
8	N/C
9	N/C
10	GND

Pinouts for Modular and Rack Mount versions of VAB720

4 Operation

The VAB720 Series is designed such that once the unit is powered on and the I/O Connectors are attached, no periodic maintenance is required.

Refer to the following installation instructions for operating the VAB720 Series.

1. Mount the VAB720T and install the power, video and audio connections
2. Measure the Optical Output power and verify that the power is the within specifications for the applicable VAB720 Series Model
3. Attach the fiber optic cable plant to the VAB720T's optical port
4. Repeat Steps 1 through 3 for the VAB720R
5. Verify that the LLINK Indicators and the RLINK Indicators are illuminated GREEN
6. Verify that the VIDEO LED Indicator is GREEN (assuming that a valid video source is connected to the VAB720T)
7. Verify that an acceptable video picture is output from the VAB720R
8. Verify audio operation using a suitable audio test source and audio receiver

Once the VAB720 System has passed the system check test, the system is available for application objectives.

4.1 Turn-On Procedure

To operate the video transmission system, connect power to the units. The green indicator "POWER" on the front panel shows that the unit is properly powered.

The green LINK lights of both units (transmitter /receiver) should be ON.
See Figure 7.0

This indicates that the receiver is receiving data from each channel. There are no adjustments to be made.

5 Maintenance and Troubleshooting

5.1 MAINTENANCE

There is no operator maintenance other than keeping the units clean and verifying that the units are operating in an environment that is within operating specifications for temperature, humidity and power.

5.2 TROUBLESHOOTING

Troubleshooting is the systematic approach to solving a problem. Each step must be performed in sequence, or erroneous test results may be obtained.

The VAB720 Series has two optical transmission indicators: LLINK and RLINK. Both the VAB720T and the VAB720R have these indicators. The LLINK always refers to the Optical Transmission Status of the

For example, if you are looking at the front panel of the VAB720R and the LLINK is illuminated GREEN, this indicates that the VAB720R is receiving a valid optical signal. If the RLINK LED is GREEN, this means that the remote end unit (e.g. VAB720T) has a valid optical signal. For troubleshooting purposes LOCAL END refers to the unit with the indicators you are observing and REMOTE END refers to the unit at the other end of the optical cable.

TROUBLESHOOTING GUIDE

The following troubleshooting procedures are based on observing the visual indicators:

TROUBLE	POSSIBLE CAUSE	CORRECTION
POWER LED OFF	<ol style="list-style-type: none"> 1. No 12 VDC Input Power (Mod) 2. Fuse Out 	<ol style="list-style-type: none"> 1. Verify the AC Power is present (1u) 2. Verify Input Power is 12 VDC (Mod/Rck) 3. Faulty Power Circuit. Return Unit
LLINK LED OFF	<ol style="list-style-type: none"> 1. No Optical Input 2. Broken Fiber 3. Remote End Off Line 	<ol style="list-style-type: none"> 1. Measure incoming Optical Power 2. Measure REMOTE END Optical Output 3. If no REMOTE END Optical Output Power, Return Unit - Faulty Laser 4. Verify Optical Fiber Integrity (label, break)
LLINK LED ON RLINK LED OFF	<ol style="list-style-type: none"> 1. No Laser Output at LOCAL END 2. REMOTE END Rx defective 	<ol style="list-style-type: none"> 1. Measure the LOCAL END's Optical output 2. Try a second unit LOCAL END UNIT 3. Return REMOTE END UNIT
VIDEO LED OFF	<ol style="list-style-type: none"> 1. No Video Source 2. Loose Connection at VAB720T 3. Defective LED Indicator 	<ol style="list-style-type: none"> 1. Verify that VAB720T VIDEO is ON 2. Verify that a Video Signal is present 3. If video signal OK, try a second TX or RX unit. 4. Faulty LED, Return Unit
Video Not Working	<ol style="list-style-type: none"> 1. No Video Source 2. Loose Connection at VAB720T 3. Defective LED Indicator 	<ol style="list-style-type: none"> 1. Verify that VAB720T VIDEO is ON 2. Verify that a Video Signal is present 3. If video signal OK, try a second TX or RX unit. 4. Faulty LED, Return Unit
Audio Not Working	<ol style="list-style-type: none"> 2. No Audio source, wrong level 3. Bad Audio cable 4. Input or Output Impedance Mismatch 5. Single Ended / Differential Interface Mismatch 	<ol style="list-style-type: none"> 1. Verify Audio Source Present and Levels 2. Verify Audio Cable construction 3. Verify Audio Source and Termination Interfaces
LLINK ON RLLINK ON No Data (Not applicable)	<ol style="list-style-type: none"> 1. Fault Cable Connections 2. Data Protocol Mismatch 3. RTS / CTS Problem 	<ol style="list-style-type: none"> 1. Verify that the cable is constructed correctly 2. Verify that the RTS / CTS is handled correctly 3. Call for Assistance
Data LED Always ON, Data OK (Not applicable)	<ol style="list-style-type: none"> 1. Faulty Cable Connections 2. Faulty Indicator 	<ol style="list-style-type: none"> 1. Verify Cable Connections. If using RS-232, only connect 3 wires. Connecting RTS/CTS to RS422 I/O will cause DATA LED to be always ON 2. Call for Assistance
Noise in Video during Data Activity (Not applicable)	Data Output is shorted to Ground	<ol style="list-style-type: none"> 1. Verify that the cable is constructed correctly. 2. Verify the terminal equipment data pins
Noise in Video when Audio Connected	Differential Audio Output to Single Ended Audio Receiver puts Noise on VAB720T or VAB720R Ground Plane	Verify the Audio Interfaces, levels and impedance's If Single Ended, verify that only the "+" is used and the Singled Ended Ground lead is connected to a VAB720 Audio GND pin

6 Specifications

6.1 Technical specification

Optical

Transmitter:	LASER
Receiver:	PIN/TIA
Wavelength:	850/1300nm Multi-mode 1310nm/1550 Single mode
Power Budget:	10dB 1F/MM 12dB 2F/MM 12dB 1F/SM 16dB 2F/SM
Connectors:	ST, FC, SC, SCAPC, FCNAPC

VIDEO

Signal Level:	1Vp-p nominal
SNR	60 dB (8 Bit), 72 dB (10 Bit)
Diff Gain / Diff Phase	2%, 2 Deg (8 Bit), 1%, 1 Deg (10 Bit)
Impedance:	75 Ohms
Bandwidth, 3dB	10MHZ

AUDIO

Input Impedance	600ohms Min.
Input Signal Level	2 Vp-p Max.
Output Impedance	600 Ohms Max.
Output Signal Level	1:1 Ratio of Input
Bandwidth, 0dB	20 Hz to 16KHz
Dynamic Range	90dB Min.
THD + N	80dB Max.
Connector	RJ48

SYSTEM

Indicators:	POWER, LLINK, RLINK, VID, DATA
Power (19" Chassis):	90 to 240VAC/47-63Hz
Power (transmitter):	12-16VDC @ 1A

TEMPERATURE

Operating:	0 ⁰ C to 50 ⁰ C
Storage:	-40 ⁰ C to 95 ⁰ C
Humidity:	95% non-condensing

PHYSICAL

Height:	1.3" (Modular/Rack) 1.75" (1U)
Width:	5.5" (Modular/Rack) 16" (1U)
Depth:	7.0" (Modular/Rack) 12" (1U)
Weight:	6.0 oz (Modular/Rack) 1.7LBS(1U)

7 Customer Support

If you ever have any questions, on products or technology, need additional products or documentation, or need to return a unit, please contact your sales representative.

7.1 Return Policy

If you have a problem with the fiber optic mode converter, check all your system connection and configuration. Also, review the troubleshooting section in this manual.

If you can't resolve the problem, contact your dealer/representative or Radiant Communications for customer service.

A Return Material Authorization (RMA) will be required before returning the unit for repair, including warranty repair. To obtain a RMA number, contact Radiant Communication's authorized service representative or distributor. To expedite return, please include the RMA.

7.3 WARRANTY

Electronics

Radiant Communications warrants to the buyer that all goods sold to the buyer will perform in accordance with the applicable data sheets, drawings or written specifications, and at the time of sale will be free of defects in material and workmanship. This warrant shall apply for a period of one year from the date of shipment, unless goods have been subject to lightning damage or other Acts of Nature, misuse, neglect, accident, damage, improper installation or maintenance, or alteration or repair by anyone other than Seller or its Authorized representative. Buyer should notify Radiant Communications promptly in writing of any claim based upon warranty, and Radiant Communications at its option may first inspect such goods at the premises of the Buyer, or may be given written authorization to Buyer to return the goods to Radiant Communications, transportation charges prepaid, for examination by Radiant Communications. Buyer should bear the risk of loss until all goods, authorized to be returned, are delivered to Radiant Communications. Radiant Communications should not be liable for any inspection, packing or labor costs in connection with the return of goods. Radiant Communications' obligations pursuant to this warranty, and sole remedies of the buyers shall be limited to the repair or replacement, or credit of the purchase price, in Radiant Communications' sole discretion.

Optical or Electrical Cables

Carefully inspect the cable upon receipt, if the cable is defective, contact Radiant Communications Customer Service Department within ten (10) days of receipt to obtain a Return Material Authorization (RMA) number before reshipping to Radiant Communications. If defective, the cable will be repaired or replaced in accordance with the warranty of the cable manufacturer, which is the sole warranty. Unless the customer order specifies that Radiant Communications shall install or supervise installation of the cable. Radiant Communications assumes no responsibility for the installation. Radiant Communications should not be liable for defective cable, cost of removing defective cable, or cost of installing replacement cable.